

Other easy-to-make projects from  
Carter Holt Harvey Woodproducts Australia  
*ask for them at your local Stylewood distributor*



Distributor

**STYLEwood®**

## Easy-to-make Children's Play Table and Chair



# Easy-to-make Children's Play Table and Chair

## PROJECT MATERIALS LIST

### TABLE MATERIALS LIST

| Component     | Material                       | Quantity          | Purchase Size & Finished Size |
|---------------|--------------------------------|-------------------|-------------------------------|
| Table Top     | Stylewood DAR                  | 3 lengths         | 240 x 19mm CUT TO 720mm       |
| Side Supports | Stylewood DAR                  | 4 lengths         | 70 x 19mm CUT TO 580mm        |
| Top Supports  | Stylewood DAR                  | 3 lengths         | 70 x 19mm CUT TO 620mm        |
| Legs          | Scantling                      | 4 lengths         | 90 x 45mm CUT TO 440mm        |
| Screws        | Countersunk Rib Head Chipboard | 18pcs of 50mm x8g |                               |
| Screws        | Countersunk Rib Head Chipboard | 44pcs of 30mm x8g |                               |
| PVA Adhesive  | To glue all joints             |                   |                               |

### CHAIR MATERIALS LIST

| Component       | Material                       | Quantity          | Purchase Size & Finished size           |
|-----------------|--------------------------------|-------------------|---|
| Back/front/seat | Stylewood DAR                  | 1 each            | 290x19mm CUT TO 1 x 500mm and 2 x 250mm |
| Bracing         | Stylewood DAR                  | 2 lengths         | 42 x 19mm CUT TO 200mm                  |
| Screws          | Countersunk Rib Head Chipboard | 14pcs of 50mm x8g |   |
| PVA Adhesive    | -                              | To glue joints    |   |

## TOOLS YOU WILL NEED FOR THE JOB

Electric hand saw • Drill & bits • Square • Router (optional)



## STEP-BY-STEP INSTRUCTIONS

### INSTRUCTIONS FOR TABLE

- STEP 1. Cut all pieces to length making sure all cuts are square.
- STEP 2. Screw side supports to legs (4 x 50mm screws into wide face of legs, 2 x 50mm into narrow face) Glue all joints.
- STEP 3. Screw top supports to side supports.
- STEP 4. Screw on the three table top pieces from underneath, using 30mm screws.
- STEP 5. Cut off corners and sand/route all edges for safety.
- STEP 6. Countersink screws and fill with woodfill putty, sand smooth and apply your choice of timber finishes.

### INSTRUCTIONS FOR CHAIR

- STEP 1. Cut all pieces to length making sure all cuts are square.
- STEP 2. Screw back leg onto seat using 3 screws. Glue all joints.
- STEP 3. Position front legs 30mm in from front of seat and screw in place, using 3 screws.
- STEP 4. Screw leg braces in place as shown.
- STEP 5. Sand/route all edges for safety.
- STEP 6. Countersink screws and fill with woodfill putty, sand smooth and apply your choice of timber finishes.

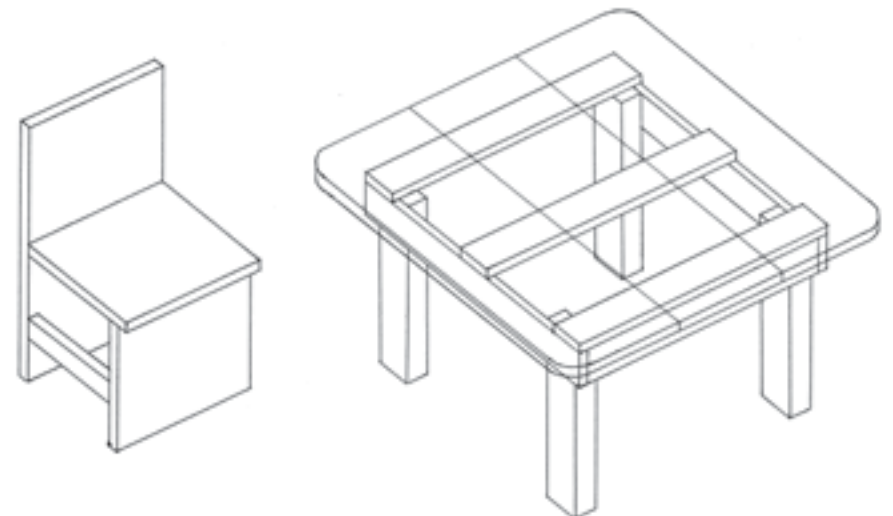

Safety warning: Inhalation of dust generated from processing Stylewood may cause irritation and sensitisation by inhalation (asthma) and by skin contact (dermatitis). Repeated inhalation of wood dust increases the risk of nasal cavity cancer and of lung fibrosis (scarring). Do not breathe dust, wear a respirator if using power tools. Phone 132 321 for a Material Safety Data Sheet.